

LibMAS 09.30

Second Edition: January 2017

EXPLOSIVE ORDNANCE DISPOSAL (EOD)

Responsible National entity:

Libyan Mine Action Centre (LibMAC)
mandated by the Ministry of Defence (MOD)

Contact: LibMAC Deputy Director

quality.assurance@lmac.gov.ly



NOTE:

This document is current at the date shown on this page. The Libyan Mine Action Standards (LibMAS) are subject to regular revision, so users should ensure that they are using the latest version of each document in the standards. The most recent versions of LibMAS are the versions that are posted on the LibMAS pages of the LibMAC website www.lmac.gov.ly

Copyright notice

This document has been written with reference to the International Mine Action Standards (IMAS).

In its current form, this document is © **LibMAC Libya 2017** – All rights reserved.

Contents

1. Introduction.....	4
2. Definitions.....	4
3. Explosive Ordnance Procedures and Operations.....	6
4. Constraints in Libya.....	6
5. Qualifications.....	7
6. Certification (Accreditation).....	8
7. Quality and Audit of Qualifications.....	9
8. Worksite Risk Assessment.....	9
9. General Requirements for EOD.....	9
10. Neutralisation and Disarming Procedures.....	10
11. Destruction Procedures.....	10
12. Safety Distances when Destroying Explosive Ordnance.....	11
13. Control of Entry into Demolition Areas.....	12
14. Transportation of Explosive Ordnance.....	12
15. Collecting Mines and ERW.....	12
16. Responsibilities.....	13
17. Reporting.....	14
18. General Initiation Methods for Demolitions.....	14
19. Standing Orders.....	15
20. Principles for Planning and Conducting Demolitions.....	16
21. Considerations for the Conduct of Demolitions.....	16
22. Use of Explosive Materials.....	17
23. Example of Preparation of Electrical Firing Circuit.....	18
24. General References.....	19
25. Record of Amendments.....	19

Annexes

- A. Safety Measures for Demolitions
- B. EOD Competencies

Foreword

Critical safety, control and quality elements of the International Mine Action Standards (IMAS) have been retained in the Libyan Mine Action Standards (LibMAS), so ensuring that they maintain the principles agreed in IMAS guidelines.

The work of preparing, reviewing and revising LibMAS is conducted by a technical committee with the support of invited international, governmental and non-governmental organisations in Libya. The latest version of each standard can be found LibMAC website. www.lmac.gov.ly

In all LibMAS the words “must”, “shall”, “should” and “may” are used in the following way. “Must” or “shall” is used to indicate a requirement, something that must be done in order to conform to the LibMAS. “Should” is used to indicate the preferred requirements, methods or specifications, but these may be varied when reasons for doing so are given. “May” is used to indicate a possible method or course of action that should be considered but need not be applied.

1. Introduction

- 1.1 This standard covers general principles for the destruction of mines and ERW found during demining work in Libya. It does not provide specific guidance about the disposal of any particular kind of explosive ordnance, the destruction of stockpiles or the disposal of ordnance not anticipated in Libya such as nuclear, biological or chemical weapons.
- 1.2 The mines anticipated in Libya are anti-personnel and anti-tank mines that may be made from plastic, steel, cast-iron, wood or even glass. The variety of ERW that may be found is also extensive, ranging from grenades, mortar and artillery ammunition, to air-dropped munitions including 120 lb fragmentation clusters and 500 lb high explosive bombs¹. Abandoned caches of munitions may also be found.
- 1.3 The variety of mines and ERW that may be present is also complicated by the fact that they may be decayed or damaged, whether or not fitted with igniters, and may have become very difficult to identify.
- 1.4 The demolition of all explosive ordnance is commonly known as Explosive Ordnance Disposal (EOD). Demining staff must be trained to a level of competence described in this standard before they can conduct any EOD demolitions.

2. Definitions

- 2.1 Pertinent definitions of terminology used within this Chapter are detailed below to aid understanding however additional terminology may be found in the LibMAS 04.10 Definitions and Abbreviations, 10.20 Demining Worksite Safety, and IMAS.

2.2 Explosives

- a. A substance or mixture of substances which, under external influences, is capable of rapidly releasing energy in the form of gases and heat.

2.3 Explosive Materials

- a. Components or ancillary items used by demining organisations which contain some explosives, or behave in an explosive manner, such as detonators and primers.

2.4 Explosive Ordnance (EO)

- a. All munitions containing **explosives**, nuclear fission or fusion materials and biological and chemical agents. This includes bombs and warheads; guided and ballistic missiles; artillery, mortar, rocket and small arms **ammunition**; all **mines**, torpedoes and depth charges; pyrotechnics; clusters and dispensers; cartridge and propellant actuated devices; electro-explosive devices; clandestine and improvised explosive devices; and all similar or related items or components explosive in nature.

¹For example, these munitions were dropped on Tripoli by USAAF 12th Air Force on 12th January 1942 <http://www.milhist.net/usaaf/mto43a.html>. Many other raids and targets are on record

2.5 Explosive Ordnance Disposal (EOD)

- a. The detection, identification, evaluation, render safe, recovery and disposal of EO. EOD may be undertaken:
 - As a routine part of mine clearance operations.
 - To dispose of UXO discovered outside mined areas, (this may be a single UXO, or a larger number inside a specific area).
 - To dispose of EO which has become hazardous by deterioration, damage or attempted destruction.

2.6 EOD Operator

- a. For the purposes of this Standard the term 'EOD Operator' refers to an Explosive Ordnance Disposal (EOD) qualified person who shall be accreditation by the LibMAC to conduct EOD procedures according to their level of EOD qualification and knowledge.
- b. When used in conjunction with EOD, the word 'Operator' is interchangeable with other terms such as 'Technician'

2.7 Demolition

- a. Destruction of structures, facilities or material by use of fire, water, explosives, mechanical or other means.

2.8 Demolition ground

- a. An area authorised for the destruction of munitions and explosives by detonation.

2.9 Destroy (destruction) in situ

- a. Blow in situ. The destruction of any item of ordnance by explosives without moving the item from where it was found, normally by placing an explosive charge alongside.

2.10 Destruction

- a. The process of final conversion of munitions and explosives into an inert state whereby they can no longer function as designed.

2.11 Central Demolition Site (CDS)

- a. An area authorised for the destruction of bulk ERW. (Annex A details considerations for locating a CDS).

2.12 Fragmentation Hazard Zone

- a. The fragmentation zone safety distance should be calculated to reduce the risk of harm from fragmentation thrown out from the explosion to those working on the worksite and to the local population. Where necessary, protective works, such as demolitions pits, earth bunds, sandbag walling or water suppression, should be used to reduce the extent of fragmentation hazard zones.
- b. Theoretical methods can be used, but the calculation of fragmentation hazard zone areas is a more complex operation than that for blast hazard zone. Various methodologies can be used, but it is accepted that the use of the "Gurney Equation" to

calculate the initial worst case fragment velocity, when combined with the “Fragment Slowdown Equation” and the effects of trajectory, gravity and air resistance can be used to estimate an acceptable danger area. This method is however complex.

- c. An alternative is to use the USA Conventional Weapons Effects (CONWEP) computer model, if available.
- d. A third approach to the calculation of fragmentation hazard zones is to use simplified equations based on experimental results combined with “Gurney Equation” predictions. These formulae utilise the all-up-weight of the munition to calculate an estimated hazard zone. It is stressed that only an appropriately qualified EOD technician should use these equations; various assumptions have to be made that are not applicable to all scenarios.
- e. **Note:** It must be understood by all involved in the estimation of explosion danger areas by calculation that these equations only predict the danger area “outside which one would not normally expect more than one significant fragment to travel”.

2.13 Multi-item Demolition Danger Area Estimation

- a. The multi-item demolition is the more likely contingency in the demining scenario. Where there are too many mines and munitions to destroy them individually in situ, and where the nature of the mines and munitions allow it, a centralised system of demolition will be used.

3. Explosive Ordnance Procedures and Operations

- 3.1 EOD operations may involve the identification, evaluation, render safe, recovery and destruction of all explosive ordnance. EOD may be a routine part of demining operations following the discovery of explosive ordnance at a worksite. EOD operations may also be undertaken to dispose of explosive ordnance discovered outside suspected hazardous areas.
- 3.2 EOD operations may involve a single item of ERW, or a large number abandoned in former storage areas. They frequently involve the demolition of a collection of mines and ERW recovered during demining operations and moved for later disposal.
- 3.3 Destroying explosive ordnance as it is found often reduces operational efficiency so mines and ERW should be moved for later demolition when it is safe to do so. Mines and ERW can only be moved by qualified EOD deminers. The EOD deminer must have been trained to assess the mines and ERW so that they can make an informed decision over which are safe to move.
- 3.4 The safety constraints for a demining workplace must be applied during all EOD activity, whether inside or outside a designated workplace.

4. Constraints in Libya

- 4.1 Demining organisations in Libya may not use or store High Explosive, detonators or detonating cord. As is the case in many other countries, this material is restricted to use

by the Libyan Armed Forces and the Civil Defence force. In many cases, a Civil Defence member may accompany a demining team to oversee the explosive demolition of discovered mines and ERW.

- 4.2 When no civil defence member is available, the demining organisation may conduct demolition by burning with controlled fires, flares, chemical powders or gases.
- 4.3 These demolition procedures must be detailed in the demining organisations SOPs that have been submitted to LibMAC for Operational Accreditation. No demolition of mines or ERW may be conducted until the procedures involved have been given Operational Accreditation by LibMAC.

5. Qualifications

- 5.1 EOD can be carried out at many levels – from the neutralization of large bombs and missiles to the destruction of grenades and sub-munitions. EOD qualifications should be appropriate to the hazard and the munitions most likely to be found.
- 5.2 The qualifications of all EOD operators shall satisfy the requirements and regulations of the LibMAS, who may request proof of capability in addition to the qualification. Detailed competencies and operating categories are in **Annex B, EOD Competencies**.
- 5.3 The following EOD qualifications shall be adhered to by Mine Action Organisations operating in Libya unless otherwise authorised by the LibMAC.

Level 1 (EOD) Qualification

A Level 1 (EOD) qualification enables the trained holder of the qualification to locate, expose and to destroy in situ, when possible, single items of mines and specific ERW on which the individual has been trained; thus Level 1 operators may be licensed to destroy on specific items of ordnance.

Level 2 (EOD) Qualification

In addition to the skills of a Level 1 (EOD) qualification, a level 2 (EOD) qualification enables the holder to determine when it is safe to move and transport munitions and to conduct simultaneous disposal of multiple items of ordnance using line mains or ring mains. This qualification extends only to those mines and specific ERW on which the individual has been trained.

Level 3 (EOD) Qualification

In addition to the skills of a Level 1 (EOD) and 2 (EOD) qualification, a level 3 (EOD) qualification enables the holder to conduct render-safe procedures and final disposal of a wide range of specific types of explosive ordnance on which the individual has been trained.

Level 3+ (EOD) Qualification

In addition to the skills of a Level 1, 2 and 3 (EOD) qualification, which covers the skills that are routinely required in Mine Action, there may be a requirement for additional specialist skills. The Level 3+ (EOD) qualification is for specialized EOD operator who have been trained in areas that needed to address specific hazards. Level 3+ competencies are listed in **Annex B, EOD Competencies**, and include the following:

- a. Clearance of Armoured Fighting Vehicles (AFV).
- b. Depleted Uranium (DU) related EO and DU hazards.
- c. Guided Weapon System AXO where the missile is fitted in the launcher.
- d. Guided missiles containing liquid propellants.
- e. Intact cluster munitions.
- f. IED Disposal.
- g. Underwater EOD.
- h. Chemical EOD.

5.4 The Level 3+ qualification shall clearly indicate the specialist training received by each individual, whether within cores or specialist competencies.

5.5 Whenever there is a requirement for specialist skills not covered in the Level 3 qualification then the LibMAS shall specify the additional skills required for a particular task, and the Mine Action Organisations concerned shall demonstrate their Level 3+ operators have the higher-level training and experience appropriate for the task.

5.6 Some ERW fall within the guidelines for the above qualification levels but present a specific or additional hazard. Examples are items containing White Phosphorous (WP, missile, or the requirement for bulk demolitions or the logistic destruction of ammunition. Special consideration should be given to the need for additional training, or for specific exclusion from the category of competence.

5.7 Where particular items are frequently encountered, specific training in the disposal of these items may be given to enable the operator to deal with them rather than continually refer the problem to the next higher level of expertise.

5.8 It should be noted that sub-munitions may be particularly hazardous to deal with and should only be dealt with by Level 2 or above qualified personnel.

6. Certification (Accreditation)

6.1 At every level of EOD competency the training organisation or authority that certifies an individual should, within the certification, explicitly list the disciplines on which the individual has been trained. At the most basic level this may include the specific munitions on which the individual has been trained to destroy or neutralise, and for more advanced levels should cover the generic competency subjects covered by the training.

6.2 To complement the certification individuals are encouraged to maintain logs of their application of the training such that demonstrate their operational experience.

7. Quality and Audit of Qualifications

- 7.1 The LibMAS and the Mine Action Organisations should develop performance criteria, appropriate assessment tools and procedures in order to assess the level and quality of competence of EOD operators. This could include written tests, practical exercises, demonstrating a task, or procedures for assessment of performance during EOD operations.
- 7.2 EOD Competencies Standards T&EP 09.30/01/2014 provides guidance on the competencies needed for EOD levels 1, 2 3 and 3+ and is designed to enhance the process of planning and evaluating EOD operators development and capacity building. Its use can also help improve the assessment of training and competency of operators involved in EOD work.

8. Worksite Risk Assessment

- 8.1 A formal and written risk assessment must be made by a pertinently qualified EOD operator for all types and conditions of explosive ordnance that are expected at a worksite. That risk assessment must detail when it is safe to move or handle an igniter device, and when it is not.
- 8.2 Explosive ordnance that is not fitted with igniter, or that is fitted with igniter but the risk assessment is that it is safe to move, should generally be moved to designated collection places in safe areas around the worksite.

9. General Requirements for EOD

- 9.1 All mines / ERW should to be destroyed in-situ unless assessed by a quailed EOD operator as being safe to move to an approved demolitions area or storage facility. Prior to moving mine / ERW, the EOD operator shall assess whether they must be neutralised or disarmed.
- 9.2 The destruction of mines / ERW is a potentially hazardous task. It is the responsibility of the EOD operator to assess the risk and ensure the correct procedures are followed to minimise that risk.
- 9.3 The following shall be observed:
- a. Safety - The safety of both personnel and property is paramount. If a method is not safe it shall not be used.
 - b. Security – Of both the items destroyed and the serviceable explosives used to destroy them
 - c. Accounting - This links with security. Any loss shall be promptly identified, investigated and reported.
 - d. Speed of Work - This shall never be a prime factor at the expense of safety, security and accounting.

- 9.4 There are many different detailed disposal procedures but certain principles apply to all disposal tasks:
- a. Knowledge - Know in detail both the item being destroyed and the explosives used to destroy it. Unless the design characteristics of both are known, it shall not be possible to determine a safe and effective means of disposal.
 - b. Planning – Plan the task in advance and leave sufficient time at the end of daily clearance activities to conduct demolitions.
 - c. Working environment - Create and maintain a safe working environment so that it is safe for the Demolition Party, other personnel, property, livestock, vehicles and equipment.
 - d. Directives - The disposal site is no place for ambiguity or misunderstanding. Directives must be clearly understood by all personnel.
 - e. Safety - Observe all the safety precautions and use only the approved methods.
 - f. Confirm - Clear the disposal area prior to departure, no disposal task is complete until the demolition area has been cleared of all hazards and contamination. Implicit in this is also the clearance of all rubbish and litter.

10. Neutralisation and Disarming Procedures

- 10.1 Depending on the formal risk assessment, explosive ordnance may be rendered safe by either neutralising or disarming it. This allows the ordnance to be transported from the worksite for demolition in another place, using approved transportation procedures.
- a. To neutralise explosive ordnance, its arming system is turned off. This is normally done by using a pin or clip to block the firing train. When the ordnance is still pinned or clipped, it is already “neutralised”.
 - b. To disarm explosive ordnance, the main body and the fuze mechanism including igniter (s) must be separated. When a detonator remains inside the body, it has not been disarmed. Neutralisation and disarming procedures should not be necessary for abandoned ordnance that has not been fitted with an igniter or primed.
- 10.2 Neutralisation and disarming procedures should not be necessary for abandoned ordnance that has not been fitted with an igniter or primed.
- 10.3 A demining organisation’s neutralisation and disarming procedures must be detailed in the SOPs presented to LibMAC for Operational Accreditation and that accreditation must have been granted before the procedure(s) are used.

11. Destruction Procedures

- 11.1 Demining organisations must prepare SOPs for the effective and safe destruction of relevant explosive ordnance. These must include the destruction of explosive ordnance in-situ and their destruction in demolition areas where they fall.

- 11.2 Demolition systems, including the use of fires, flares, chemical powders or gases must be accredited in and must be detailed in the SOPs presented to LibMAC for Operational Accreditation. Accreditation must have been granted before work procedures can be started.
- 11.3 Explosive ordnance shall be destroyed by the Mine Action Organisation on the day it is located or collected at the worksite, unless otherwise authorised by the LibMAC, in which case a date by which time it must be destroyed shall be agreed with the LibMAC.

12. Safety Distances when Destroying Explosive Ordnance

- 12.1 The Mine Action Organisations SOPs shall include the safety distances for the destruction of explosive ordnance, detailing the demolition systems employed, including the use of fires, flares, chemical powders or gases. The SOPs must be approved for use by the LibMAC.
- 12.2 Safety distances during explosive demolition are greater than working distances during clearance procedures (as detailed in LibMAS 10.20 Demining Worksite Safety), because there is a deliberate intent to cause a detonation, and there shall be no other demining work to be conducted within the safety distance, while the demolition takes place.
- 12.3 For further details pertaining to demolition safety distances refer to **Annex A Safety Measures for Demolitions**.
- 12.4 Table 1 below details the minimum safety distances for the demolition of mines.

Mine Type (a single mine and minimum demolition charge is presumed)	Minimum safety distance (in metres)	
	Demolition staff	Other staff
AP blast (all types)	25	60
AP fragmentation mines (all types)	60	100
AT mines	200	300

Notes:

1. Recommended minimum distances are for demolition staff wearing IMAS compliant PPE (as detailed in LibMAS 10.30 Personal Protective Equipment). Other staff not wearing PPE should be out of line of sight from the demolition at the time of the detonation. Ear protection should be provided to demolition staff at the time of demolition when the risk appears at the minimum distance above.
2. The distances shown are between the site of the detonation and the position of staff at the time of the demolition not distances between demining staff. The safety distances may be reduced if there is a safe place with adequate protection available in the area for example, inside a bunker or behind a hillside.
3. While using protective works while destroying mines by explosive demolition, the required safety distance should be assessed by appropriately qualified staff and may be reduced to

reflect the reduced risk.

4. When multiple mines are being destroyed in a single demolition, the all-up weight (AUW) of the high explosive involved should be considered and an appropriate safety distance should be determined and applied.
5. Reference should be made to Annex A of this standard for additional details pertaining to safety distances for demolitions.

Table 1: Minimum Safety Distances during Demolition of Mines

13. Control of Entry into Demolition Areas

- 13.1 When demolitions are being conducted, procedures must be enforced that give complete confidence that local people and their livestock will not enter the safety distance for the demolitions taking place.

14. Transportation of Explosive Ordnance

- 14.1 Explosive fitted with ignitors should not be moved from the worksite when their transportation entails an unnecessary risk
- 14.2 Explosive ordnance fitted with ignitors which are neutralised or have been rendered safe, may be moved from the worksite (using suitable transportation) for demolition in another place. When this occurs, ignitors and detonators must be transported separately from the main bodies of explosive ordnance.
- 14.3 Transportation of any explosive ordnance over paved public roads can only be conducted with the permission of the appropriate local authorities.
- 14.4 Procedures for the transportation of explosive ordnance must be detailed in the Mine Action Organisations SOPs presented to LibMAC for Operational Accreditation, and Accreditation must have been granted before any explosive ordnance is transported.

15. Collecting Mines and ERW

- 15.1 Collection points must be established at any worksite where explosive ordnance is moved for demolition. Collection points must have separated areas for explosive ordnance of each type, and for ordnance that has been neutralised or disarmed and ordnance that is live. Ignitors and detonators should be stored separately. For additional details refer to LibMAS 10.20 Demining Worksite Safety.
- 15.2 When the destruction of explosive ordnance is not conducted while work is continuing inside the suspected hazardous area, the collection points and the demolition area can be inside a cleared area.
- 15.3 The Collection points and demolition areas must be separated when the demolition area is not big enough to ensure that devices in the collection area are secure during the demolition of other items.
- 15.4 Details for the collection of explosive ordnance must be given in the Mine Action

Organisations SOPs presented to LibMAC for Operational Accreditation, and Accreditation must have been granted before explosive ordnance is collected

16. Responsibilities

a. Libyan Mine Action Centre (LibMAC)

LibMAC shall:

- Establish and maintain records of approved EOD procedures;
- Establish and maintain national records of the qualification of EOD operators; and
- Provide Quality Assurance monitoring of EOD procedures.

b. Mine Action Organisations

Mine Action Organisations shall:

- Gain Operational Accreditation from LibMAC for all EOD procedures;
- Ensure that the EOD operators are competent and suitably trained; and
- Ensure that the affected community is aware of all EOD activities in the area and the implications for the community (particularly related to the depth of search).

16.1 Mine Action Organisations Responsibility for Demolitions

16.1.1 EOD operators are only authorised to deal with those items and situations for which they have been accredited.

16.1.2 The EOD Operator is ultimately responsible for the co-ordination and control of all demolition activities.

16.1.3 This is to include the activities listed below, both in the field and at a demolition range practice.

- a. Selection and clearance of the demolition area.
- b. Handling of explosives.
- c. Testing of detonators, electrical cable and safety fuse.
- d. Preparation and placement of all explosive charges.
- e. Maintaining standards in accordance with safety regulations (including the co-ordination and control of sentries).
- f. To warn the required local authorities, local military establishments, police stations and surrounding residences of the demolition.
- g. Control of the demolition.
- h. Clearance of the demolition area after detonation of charges.
- i. Completion of reports.

16.2 Authority for Demolitions

16.2.1 No demolitions shall be conducted without prior authorisation by the LibMAS. Approval may be included in the tasking and / or implementation plan or given on

request, i.e. for EOD spot tasks.

17. Reporting

- 17.1 The planned destruction of mines / ERW located should be conducted by the end of each day unless a specific safety hazard (or lack / limited amount of explosives) prevents this.
- 17.2 Where mines / ERW are not destroyed on the day that they are found, they are to be accurately reported in the Mine Action Organisation's daily task log (or similar) and destroyed as soon as possible. If they are not destroyed by the end of the working week, the Mine Action Organisation is to ensure they are included on the weekly progress report (or similar) for the task submitted to the LibMAC, and an explanation given.
- 17.3 EOD Reporting – Comprehensive IMSMA reports (or other authorised reports) are required following the completion of an EOD task.
- 17.4 The destruction of a single item of ERW (spot EOD task) shall be recorded in the IMSMA Dangerous Area Report (or other authorised report), ensuring the appropriate section on EOD spot tasks is completed. All other EOD tasks are to be recorded in the IMSMA Progress Report (or other authorised report).
- 17.5 A Notice to Air Movement (NOTAM) or a similar notice for demolitions, shall be submitted when the total of any one explosive charge exceeds the maximum approved limit for that particular area, this includes the explosive quantity of the donor charge. The only exception to this rule is demolitions within **1 km** of any airport or main helicopter landing site (HLS), which require a NOTAM at all times.

18. General Initiation Methods for Demolitions

- a. The following details two general initiation methods for Demolitions used in Libya:

18.1 Electrical

- 18.1.1 Involves the use of an electrically initiated detonator, firing cable and a power source and ensures a near instantaneous destruction of mines / ERW; this is the **preferred method of disposal** and has the following advantages over the non-electrical method:
- Control is maintained until the precise moment of firing
 - Firing point is sited outside the danger area
 - Misfire waiting period is 10 minutes as opposed to 30 minutes when the non-electrical method is used.
 - The risk of premature initiation is reduced provided that all the relevant safety precautions have been carried out.

18.2 Non Electrical

18.2.1 Involves the use of a non-electric detonator, safety fuse and an initiation system. This method is recommended in areas with a high Radio Frequency (RF) hazard and in the event of thunder (electrical) storms. Due to the nature of the safety fuse (i.e. low explosive) a delay between initiation and detonation is expected.

19. Standing Orders

19.1 Maximum fragmentation range - This determines the danger area and all persons and equipment shall be outside this area. The perimeter of the disposal site shall contain the danger area. The size of the disposals area shall therefore limit the permissible size of demolition charges. No demolition shall be permitted above the level where fragments may travel further than the perimeter

19.2 Sentries are critical to the safety of demolitions and are to be positioned at every possible entry point of the cordon, set sufficiently clear of the demolition site and danger areas.

19.3 Sentries are to be carefully briefed about their duties, in particular about warnings and stand-down instructions. They are to be equipped with communications to reach the EOD operator and each other.

19.4 Radios must not influence demolitions, and are to be tested before and after the sentries are posted.

19.5 The EOD Operator should brief the sentry on the following duties:

- a. The exact location of his/her post and area of responsibility.
- b. The location of other sentries on the cordon.
- c. Planned timing of demolition
- d. Call-signs and signals
- e. Action on misfires, accidents, unauthorised entry into danger area by persons or animals.
- f. Radio checks timings. As a minimum on manning his/her post and immediately prior to planned demolition time.
- g. Duration of sentry duties and actions for recall i.e. only the EOD Operator may recall the sentries.
- h. Action to be taken to prevent people moving into the danger area.
- i. Action to be taken should anyone ignore the sentry and continues into the danger area i.e. inform the EOD Operator immediately.
- j. Action to be taken on loss of communications i.e. remain at his/her post and continue to prevent entry into the danger area until relieved.

19.6 Marking of the site - Disposal sites shall be marked with notice boards sited so that they are visible on all possible approaches.

19.7 Location of the firing point - This shall be close enough to allow the EOD operator to maintain effective control over the demolition and the cordoned area. The firing point shall be located outside the danger area however, in exceptional circumstances may be located within the danger area provided sufficient protection is provided to the firing party.

- 19.8 Communications - Reliable communications between all parties involved in the disposal are essential to safety. The EOD operator shall regularly test communication with sentries and medical support. If communication is lost then all activities shall cease until restored.
- 19.9 During demolition operation, medical support and casualty evacuation shall be according to LibMAS 09.40 Medical Support to Demining.

20. Principles for Planning and Conducting Demolitions

- 20.1 Demolitions should be planned and conducted in the following sequence:
- a. Identify target.
 - b. Plan cordons, medical support, brief sentries and warn local people and authorities.
 - c. Establish a safety cordon around the danger area.
 - d. Prepare demolition charge.
 - e. Place charges.
 - f. Warn sentries and local people that a demolition is about to occur.
 - g. Observe area.
 - h. Initiate demolition if "all clear".
 - i. All personnel are instructed to look up and observe for falling fragments or debris as a result of the demolitions.
 - j. Check demolition safely completed.
 - k. Lift cordon.

21. Considerations for the Conduct of Demolitions

- 21.1 The effects of the explosion (i.e. blast and fragmentation) and safety measures (i.e. safety distances, protection and cordon) should be calculated and adhered to prior to commencing the demolition.
- 21.2 The minimum number of persons should be employed in the preparation of the charges; all other personnel shall stay at the firing point and / or other place of safety until the EOD operator instructs otherwise.
- 21.3 All explosive charges used for the destruction of mines / ERW are to be calculated to be of sufficient quantity to ensure complete destruction of at least the explosive components, rendering them safe. The type, age, and origin of explosives used may dictate the amount of charge required.
- 21.4 The demolition explosive charge should be placed as close as possible, without touching the mines / ERW assessed as being a UXO, unless in a safe condition, i.e. unfused. The demolition explosive charge shall not be placed in contact with mines / ERW assessed as being in an unstable condition.
- 21.5 The EOD operator should ensure that shock-wave transmission is directed to the main explosive charge of the mine / ERW. The charge should also be placed so as to guarantee that the blast and fragmentation are directed away from vulnerable areas.

- 21.6 Protective works (i.e. sand bags) should be used to reduce the effects of detonation, when required.
- 21.7 The demolition ('last step' – connecting detonator/s) shall be conducted by one person however there may be a requirement for other personnel to monitor the process (i.e. during training and QA).
- 21.8 The EOD operator and/or person managing the demolitions, should ensure that the sentries are alert, that the area is clear and that all team members are accounted for.
- 21.9 During demolitions, all personnel are to take cover and if possible, look upward for falling debris when the detonation has occurred.
- 21.10 In case of a misfire, a wait time of ten (10) minutes for an electrical misfire and thirty (30) minutes for a non-electrical, should be enforced. After the appropriate time the EOD operator, should approach the charge and place a fresh charge next to the charge that has not fired, or, disconnect the firing circuit, depending on the decision of the EOD operator as to which procedure to use **and in accordance with the Mine Action Organisations SOPs**. The charge that has not fired must never be touched.
- 21.11 After initiating the demolition, the EOD operator should go forward to check that all charges have fired correctly, for any other hazard, and to announce the 'all clear'.

22. Use of Explosive Materials

- 22.1 Mine Action Organisations SOPs shall detail procedures for the transportation, storage and handling of explosives in Libya.
- 22.2 The following are guidelines for the use of explosives in the absence of details in Mine Action Organisations SOPs. Reference shall be made to IMAS 10.50 for additional details for the transportation, storage and handling of explosives.
- 22.3 Smoking is forbidden within 25m of any explosives (including explosives in their containers).
- 22.4 When not in use, explosives shall be stored in their containers and every effort shall be made to protect electrical detonators from the effects of electro-magnetic radiation, i.e. transported in metal containers.
- 22.5 Detonators are to be treated with care, not left unattended and kept separately from other explosives (including detonating cord) until they are introduced into the planned firing circuit/demolition train.
- 22.6 Prior to handling electrical detonators anti-static precautions shall be conducted, to remove any potential static electric charge.
- 22.7 Detonators and safety fuse shall not be buried under any circumstances, as they may malfunction and / or become damaged.

- 22.8 As previously detailed, the preferred method of demolition initiation is by using electrical means and shall be used whenever possible.
- 22.9 Electrical detonators should be tested prior to their use with an approved device, to ensure serviceability. The detonator test shall be conducted by an EOD operator and sufficient protection shall be afforded to the EOD operator during the test, i.e. detonator behind sandbag and / or EOD operator wearing PPE. The test shall be conducted at an appropriate safe distance from other people.
- 22.10 If a cable or detonator fails the continuity test it shall be removed from use for further testing and/or disposed of.
- 22.11 Exposed electrical detonators (separated or as part of the explosive circuit) shall be at a minimum distance of 300 metres from sources of high electro-magnetic radiation (i.e. radio or radar transmitting station); 160 metres from high frequency (HF) radios and 25 metres from very high frequency (VHF) radios. This distance may be revised based on the power of the source and, is not pertinent if the source is confirmed to be non-operational.
- 22.12 Safety fuse shall be handled and stored with care at all times. Safety fuse is susceptible to moisture and therefore the ends shall be sealed when not in use and especially when transporting in vehicles and in storage.
- 22.13 Each coil of safety fuse or remnant of a coil is to be subjected to a test burn immediately before use. A minimum of 30 cm from both ends of safety fuse shall be discarded prior to the test burn.
- 22.14 **Note:** In circumstances where the same coil is immediately used again then there is only a requirement to discard a minimum of 30 cm from the end to be used, as long as the remainder of the coil is at least 30 cm longer than that to be used for the initiation process
- 22.15 As a minimum, 60 cm of safety fuse shall be used for the non-electrical method.
- 22.16 One alternative to using a coil of safety fuse is to use a 'detonator complete' (detonator pre-crimped to a length of safety fuse). **Note:** This shall be stored with detonators and separated from other explosives.

23. Example of Preparation of Electrical Firing Circuit

- 23.1 Electrical firing cable should two-strand, twisted cable and, shall be tested for serviceability and continuity before use.

- 23.2 The firing cable shall be deployed from the firing point to the demolitions point or in reverse
- 23.3 Once deployed and not in use, the firing cable should be protected from the effects of electromagnetic radiation, ends twisted and/or grounded.
- 23.4 A continuity test should be conducted of the complete circuit prior to initiating the firing device.
- 23.5 If the resistance (i.e. in ohms) of the electrical firing cable, detonators or complete circuit is not as required, the demolition shall not proceed until the correct measurement is achieved.

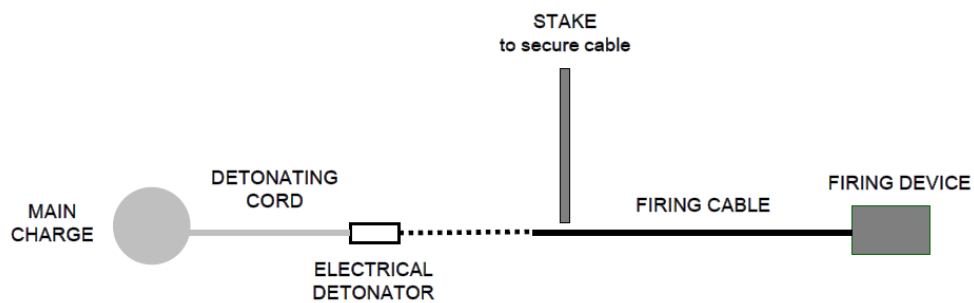

Figure 1: Example of Electrical Firing Circuit

(Note: Detonating cord may not be required)

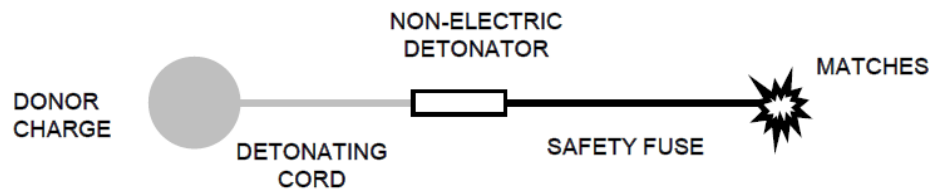

Figure 2: Example of Non-Electrical Firing Circuit

(Note: Detonating cord may not be required)

24. General References

- a. International Mine Action Standards (IMAS), in particular, 09.30 Explosive Ordnance Disposal, 10.50 Transportation, storage and handling of explosives.
- b. LibMAS 03.40/1 Detectors, 04.10 Definitions and Abbreviations, 10.20 Demining Worksite Safety, 10.20/1 Demining Site Marking Systems.

25. Record of Amendments

Ser.	Date: D/M/Y	Standard	Section / Paragraph	Amended by: Name / Position / Org.	Comments
1	13/10/15	09.30 Explosive Ordnance Disposal	All	Doug Ware, Chief of Ops/QA, UNMAS	Revised and add. details to existing Standard
2	13/10/15	09.30 Annex B	All	Doug Ware, Chief of Ops/QA, UNMAS	New Standard
3	13/10/15	09.30 Annex C	All	Doug Ware, Chief of Ops/QA, UNMAS	New Standard