

LibMAS 09.10/1

Annex B

Second Edition: January 2017

INVESTIGATING A DETECTOR SIGNAL AND FULL EXCAVATION

Responsible National entity:

Libyan Mine Action Centre (LibMAC)
mandated by the Ministry of Defence (MOD)

Contact: LibMAC Deputy Director
quality.assurance@lmac.gov.ly



NOTE:

This document is current at the date shown on this page. The Libyan Mine Action Standards (LibMAS) are subject to regular revision, so users should ensure that they are using the latest version of each document in the standards. The most recent versions of LibMAS are the versions that are posted on the LibMAS pages of the LibMAC website www.lmac.gov.ly

Copyright notice

This document has been written with reference to the International Mine Action Standards (IMAS).

In its current form, this document is © **LibMAC Libya 2017** – All rights reserved.

Contents

1. Introduction.....	3
2. Actions on a Detector Signal.....	3
3. Additional Requirements for Actions on a Detector Signal.....	3
4. Investigating a Detector Signal by Excavation.....	4
5. Investigating a Detector Signal by Prodding and Excavation.....	6
6. Recommended Prodding and Excavation Procedure.....	6
7. Full Excavation.....	7
8. Additional Requirements for Investigating a Detector Signal by Excavation and Prodding, and for Full excavation.....	8
9. Cautionary Points Concerning Anti-personnel 'Box' Type Mines.....	9
10. Actions on Locating a Mine/ERW or other Hazardous Object.....	9
11. Additional Requirements for Actions on Locating a Mine/ERW or other Hazardous Object.....	10

1. Introduction

1.1 This Annex details procedures for investigating a detector signal and full excavation.

2. Actions on a Detector Signal

2.1 On hearing/noticing a detector signal the Deminer shall conduct the following:

- a. Make a 'mental note' that there is a signal however complete the detector search to the maximum required distance forward of the base stick (B/S) and minimum overlap distance to the sides, to confirm whether there are any further signals.
- b. If it is safe to continue the search then make a 'mental note' of any further signals (if applicable).
- c. Note: it may be determined that it is not safe to continue with the search (i.e. if searching dense vegetation, if there is a possibility of disturbing mines/ERW or trip wires, etc. during the search), in which case the detector search shall cease pending a risk assessment and/or investigation of the signal.
- d. If a signal(s) was identified, the detector search should be repeated from the start point (to ensure that the nearest signal is located first).
- e. On detecting a signal, isolate it using the search head and place 3 isolation markers at the extremities of the signal (front, left and right), or other approved markers. Additional signals may be isolated if necessary however the nearest shall be investigated first. Note: the LibMAC may approve the Mine Action Organisation to use alternative markers.
- f. Visually inspect the isolated signal and identify any surface metal.
- g. If safe to do so, carefully remove the surface metal.
- h. Check the isolated signal again and if there is a signal, conduct the signal investigation procedure.
- i. If, after check the isolated signal again there is no signal, remove the isolation markers (conduct the same process for all isolated signals).
- j. If there are no signals and all isolation markers have been removed, start the complete detector search procedure again from the beginning, prior to moving the B/S forward.
- k. Note: In circumstances where there are multiple signals then the Deminer shall seek the advice from the supervisory person (i.e. Team Leader) as to the appropriate action, i.e. investigate individual signals (starting with the nearest), conduct full excavation, mark and bypass (opening a new demining lane).

3. Additional Requirements for Actions on a Detector Signal

- a. All detector signals within the designated search area to the front of the lane (B/S) and the minimum 10cm overlap to the sides shall be investigated.
- b. When isolating and marking a signal the person conducting the procedure shall face towards the immediate area to be marked.
- c. Prior to investigating the detector signal, the precise location of the signal shall be identified and marked.
- d. Nothing shall be placed on the area of the detector signal.

- e. No attempt shall be made to mark the rear of the signal from this position.
- f. If it is deemed necessary, then, it should be approached from a cleared area from another side.
- g. Extreme caution shall be taken when using the signal markers to ensure that they are carefully positioned outside the site of the signal.

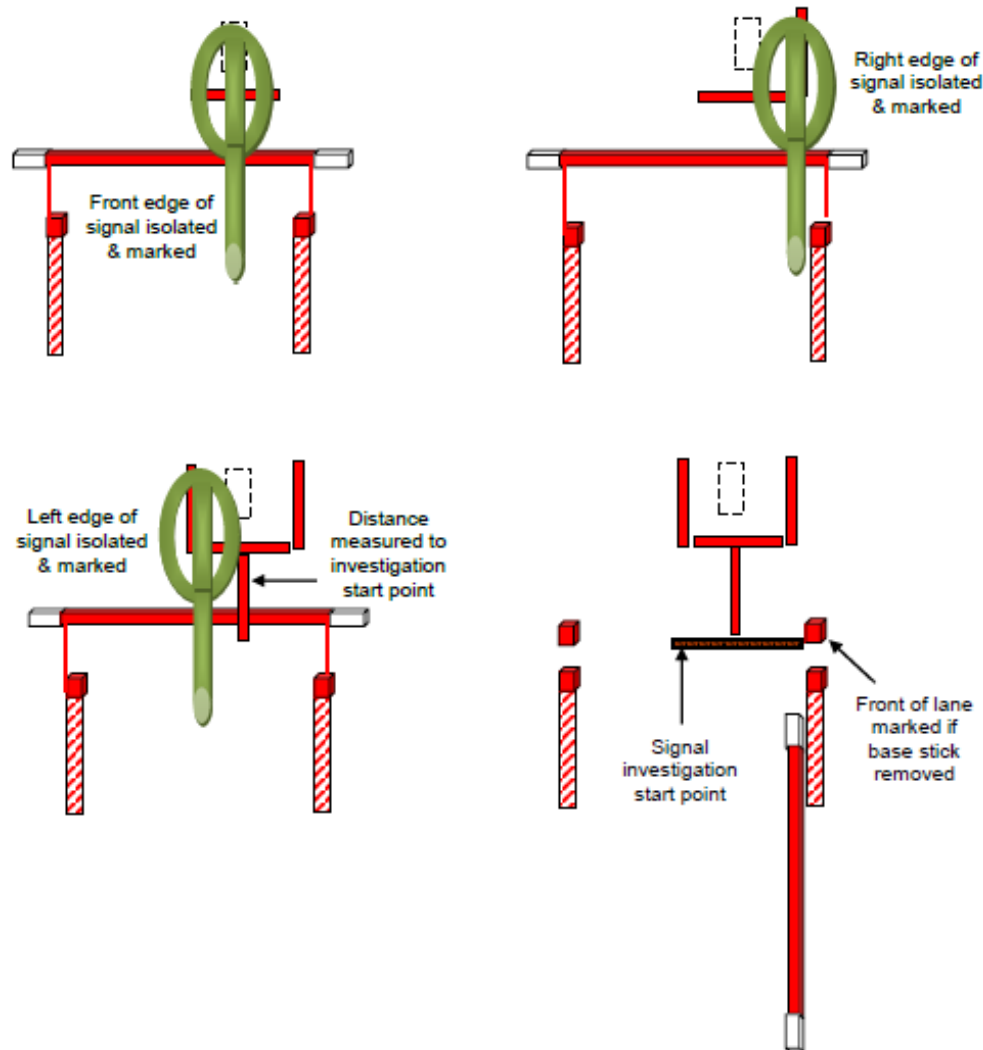

Figure1: Example - Actions on a detector signal

4. Investigating a Detector Signal by Excavation

4.1 The following details the minimum requirements for investigating a detector signal by excavation:

- a. A visual inspection of the area to be investigated (isolated signal) shall be conducted prior to commencing the investigation process.

- b. Any loose metal on the surface should be removed, if it is safe to do so, and the area rechecked using the detector.
- c. The Deminer shall measure a minimum of 13 cm back from the front isolation marker (nearest edge of signal) to the closest point for the start of investigation.
- d. The Deminer shall ensure that the front forward edge of the lane is marked using a B/S, red topped wooden posts or red rocks (red/white if authorised by the LibMAC).
- e. The B/S may be removed by the Deminer to ease the investigation process however prior to this two red topped wooden posts or red rocks (red/white if authorised by the LibMAC) shall be positioned inside the front right and left sides of the B/S within lane marking cord/tape.
- f. The investigation process shall commence a minimum of 13 cm back from the nearest point of the signal and to the required width, which, is dependent on the size of the signal.
- g. At the investigation start point, the Deminer should then excavate as a minimum, a 13 cm deep trench with a vertical flat face. The trench should be at least as wide as the isolated signal.
- h. A trench shall be carefully excavated towards the signal using the approved tool (i.e. scraper, trowel) in a safe and methodical manner. This should be conducted from the bottom of the trench to the top from side to side. Any excessive pressure and abrupt movements with the tool shall be avoided.
- i. Any pertinent non-hazardous metal found shall be removed to the relevant container, and the ground re-checked with the detector. When no signal remains within the 13 cm deep trench, the Deminer shall continue ahead.
- j. Note: depending on a risk assessment, the Deminer may be required to excavate the ground deeper.
- k. The investigation process shall continue until the signal has been cleared and/or a hazardous object identified, in accordance with clearance requirements.
- l. If the Deminer exposes a portion of what he recognises to be a mine/ERW or other hazardous object, he/she shall stop all excavation. The Deminer shall **only** expose the absolute minimum part of the object to assist in recognition.

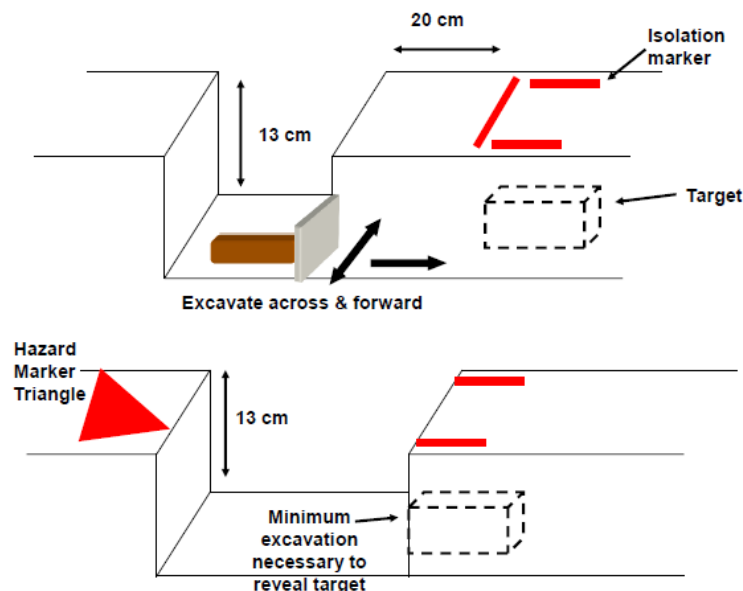

Figure 2: Investigating a detector signal by excavation

(Note: Triangle placed in safe area on locating mine/ERW or other hazard)

5. Investigating a Detector Signal by Prodding and Excavation

5.1 The following details the minimum requirements for investigating a detector signal by excavation:

- a. In accordance with 3. Investigation of a Detector Signal by Excavation, points a – f.
- b. Note: The depth prodded should be dependent on the ground conditions, clearance depth and tool design however, shall not exceed 10 cm prior to the ground being investigated through excavation. This is to ensure that undue pressure is not exerted while prodding deeper.
- c. At the investigation start point, if it is not possible to conduct prodding from the surface of the ground to the required depth, then a certain amount of excavation shall be conducted in order to achieve the required prodding depth. Alternatively, the prodding procedure may be replaced with excavation only.
- d. All prodding shall be at an angle of no greater than 30 degrees and the ground should be prodded at intervals of no greater than 2.5 cm.
- e. The prodder shall be used with an even motion, avoiding any excessive force or stabbing.
- f. After the location and if possible the size of the source of the signal has been established, the hand-trowel, scraper (or other approved tool) shall be used to excavate the soil to reveal its identity. The prodder may be used to carefully remove the soil (i.e. scraping sideways) however this shall be on approved by the LibMAC.
- g. Any pertinent non-hazardous metal found shall be removed to the relevant container, and the ground re-checked with the detector. When no signal remains within the 13 cm deep trench, the Deminer shall continue ahead.
- h. Note: depending on a risk assessment, the Deminer may be required to excavate the ground deeper.
- i. The investigation process shall continue until the signal has been cleared and/or a hazardous object identified, in accordance with clearance requirements.
- j. If the Deminer exposes a portion of what he/she recognises to be a mine/ERW or other hazardous object, he/she shall stop all excavation. The Deminer shall **only** expose the absolute minimum part of the object to assist in recognition.

6. Recommended Prodding and Excavation Procedure

6.1 The following details a recommended prodding and excavation procedure:

- a. Prodding and excavation shall be conducted from the kneeling position (i.e. both knees on the ground).
- b. After digging a trench a minimum of 13 cm deep with a vertical face, the prodding shall start from the of bottom right or left side of the trench face forward to a maximum distance of 5 cm along the trench face at maximum intervals of 2.5 cm.
- c. In order to achieve a prodding angle of less than 30 degrees, the prodder should be held as horizontal to the ground as possible.

- d. On completing the prodding procedure at one level, the prodder is moved a maximum distance of 2.5 cm upwards and the process repeated until the complete trench face is prodded.
- e. The trench shall be excavated forward the distance prodded (i.e. a maximum of 5 cm) after which, the prodding process is repeated.
- f. Any solid objects indicated by the prodder shall be investigated visually and thorough excavation if necessary.

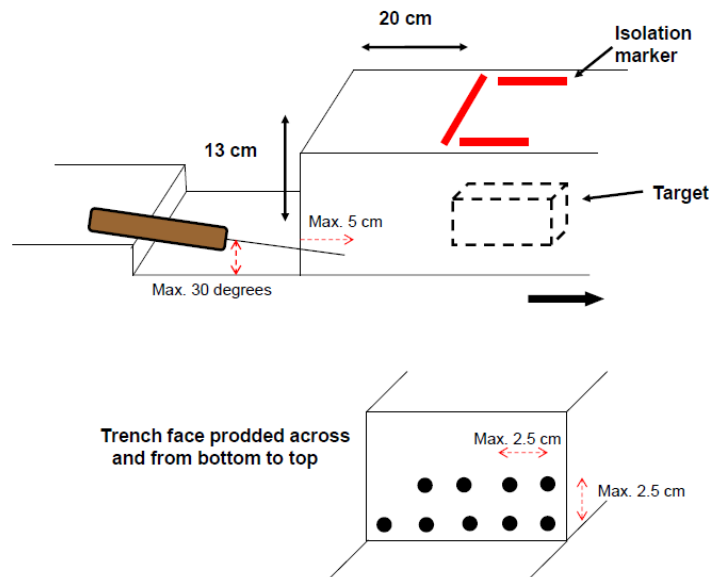

Figure 3: Example - Investigating a detector signal by prodding and excavation

7. Full Excavation

7.1 In certain areas the detector may be ineffective and therefore, the procedure should be replaced with a full excavation procedure to ensure that all mines/ERW are located to the required depth. The following are examples of when Full Excavation may be required:

- There is substantial metal contamination in the soil, making it impossible to distinguish signals.
- The area contains mineralised or magnetic soil detectors with the ability to ground compensate (ground balance) are not available, or unable to prevent interference.
- The maximum depth that mines are anticipated to be found is beyond the range of the detectors (i.e. deep buried deliberately or through earth movement).
- The detector is inoperative or adversely affected (environment, electro-magnetic radiation).
- There is a requirement to investigate or remove obstacles, e.g. trenches, bunkers, mounds, rocks, fences.

7.2 The following details the minimum requirements for conducting full excavation:

- a. The minimum depth excavated shall be 13 cm. The full width of the 1 metre wide demining lane and a minimum of 10 cm to each side of the lane (overlap) shall be investigated to this depth.
- b. The Deminer shall create a trench a minimum width of 1.2 metres with a vertical flat face, a minimum of 20 cm back from the nearest detector signal (obstacle, etc.) to a minimum depth of 13 cm.
- c. The trench shall be carefully excavated forward by using the approved tool in a side - to- side pattern and should be conducted from the bottom of the trench to the top. Any excessive pressure and abrupt movements with the tool shall be avoided.
- d. As the detector is not being used to identify any signals; there may be no prior indicator that a mine/ERW is present and therefore, the Deminer must be cautious.
- e. The detector should be used to check regularly the soil contamination level and confirm whether the full excavation process can be replaced with the detector search procedure.
- f. The prodder may be used during the full excavation process, similar to that described in 4. Investigating a Detector Signal by Prodding and Excavation.
- g. When the B/S is used in the prodding process, it should be marked at a maximum of 2.5 cm intervals across its length which should assist the Deminer in maintaining the required distance.

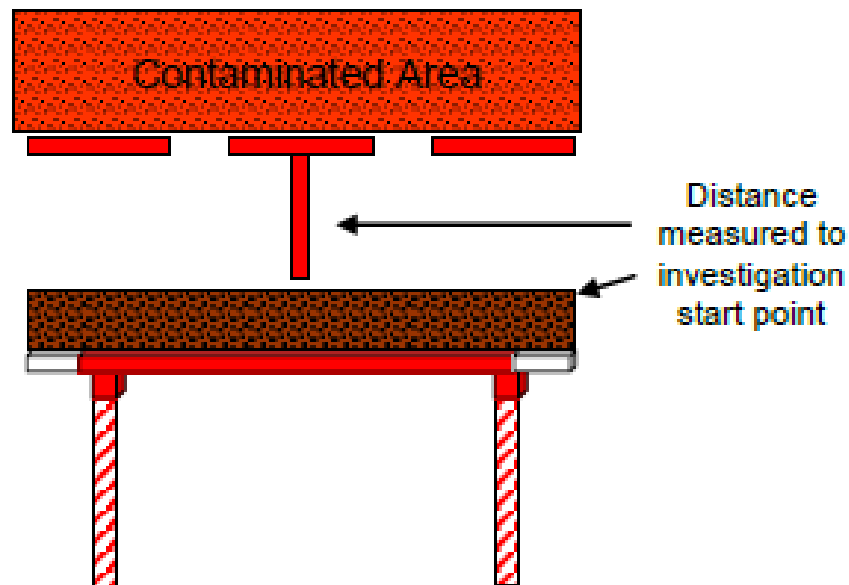

Figure 4: Full Excavation

8. Additional Requirements for Investigating a Detector Signal by Excavation and Prodding, and for Full excavation

- 8.1 The following are additional minimum requirements for investigating a detector signal by excavation and prodding, and for full excavation:

- a. When investigating a signal or conducting full excavation, the person conducting the procedure shall face towards the immediate area to be investigated.
- b. The precise location of the signal shall be clearly marked prior to commencing the investigation process.
- c. A metal detector should be used to assist during the process signal investigation process.
- d. The signal investigated and full excavation shall be conducted from a clear area using a safe/methodical technique with the aim of avoiding any disturbance to mines/ERW or other hazardous.
- e. All effort shall be made to avoid excavating or prodding on top of mines/ERW, in particular when working in areas suspected or confirmed to contain anti-personnel pressure blast mines.
- f. In hard ground, i.e. resulting from extremely dry conditions, water may be used to soften the ground prior to commencing the signal investigation or full excavation process. This shall be applied with caution and in moderation to avoid unnecessary disturbance of the ground
- g. The Deminer shall expose the absolute minimum of the object to assist in recognition.
- h. Consideration should be given to augmenting monitoring of the Deminer during the investigation process (i.e. more frequent) as a high proportion of the demining accidents may have occurred while conducting this procedure

9. Cautionary Points Concerning Anti-personnel 'Box' Type Mines

- a. Extreme vigilance shall be exercised when working in areas suspected or confirmed to contain anti-personnel pressure blast 'box' type mines (e.g. Iranian No 4 or Russian PMD-6) which incorporate a fuze protruding from the end, particularly as the fuze safety (release) pin may have decayed, pushed out or missing.
- b. The detector should be used where possible to assist during the signal investigation process and information such as survey and minefield records should be reviewed to understand the most safe and effective method of approach.
- c. In circumstances where the orientation of the mine is uncertain or investigation towards the fuze is unavoidable then extra caution shall be taken to avoid any disturbance to the fuze.



Figure 5 and 6: Iranian No 4 and Russian PMD-6 AP Mines (*Reference: Google website*)

10. Actions on Locating a Mine/ERW or other Hazardous Object

10.1 On seeing what he/she believes to be a mine/ ERW or other hazardous object the Deminer shall conduct the following:

- a. Stop the investigation (i.e. excavation, prodding), mark the item with a standard hazard marker (red wooden triangle) at a minimum of 10 cm before the object, and inform the pertinent supervisory staff
- b. Supervisory staff (i.e. Team Leader) shall conduct a visual inspection of the item with the aim of confirming its location, type and condition. If necessary, additional technical advice may be sought.

- c. If it is confirmed that the item is hazardous then the supervisory staff shall decide on the appropriate actions in accordance with the Mine Action Organisation SOPs, i.e. close the demining lane (see LMAS 10.20/1 Demining Site Marking Systems), remove, or destroy the item in-situ.
- d. The Deminer may be instructed to continue clearance, i.e. redirect the demining lane or start a new demining lane to safely by-pass the located mine/ERW or other hazardous object, or continue in the demining lane after it has been dealt with.

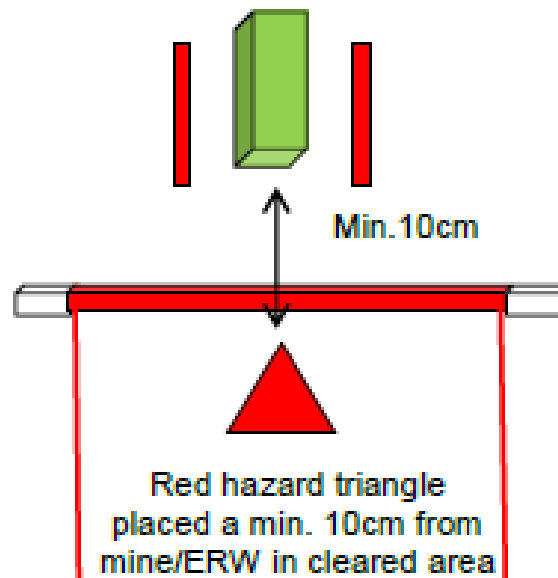

Figure 7: Marking a located mine/ERW or other hazardous object

11. Additional Requirements for Actions on Locating a Mine/ERW or other Hazardous Object

- 11.1 The following are additional minimum requirements for actions on locating a mine/ERW or other hazardous object:
 - a. During mine clearance operations, no personnel shall be allowed to pass
 - b. located mines/ERW or other hazardous objects in a 1 metre wide demining lane until it has been removed or destroyed.
 - c. In circumstances where the mine/ERW is not destroyed or removed immediately, the Deminer shall be moved to an alternative demining lane or the lane shall be redirected to safely by-pass the mine/ERW or other hazardous object.
 - d. No personnel shall traverse the ground within 20 cm of a located mine/ERW or other hazardous object.
 - e. Where possible all located mine/ERW or other hazardous objects other should be destroyed in situ.
 - f. If this is not possible, or proves to be impractical, the mine/ERW or other hazardous object shall be neutralised and/or disarmed and moved to a secure location, in accordance with procedures detailed in the Mine Action Organisation SOPs (or other documents approved by LibMAC).
 - g. If it is suspected that mines/ERW or other hazardous objects are booby-trapped then they should be safety moved (i.e. by remote pulling) prior to handling.

- h. Mine/ERW and other hazardous objects located during mine clearance shall be removed from the demining site or destroyed at the site on the same day located, unless the LibMAC has approved for them to remain at the site.
- i. All mines/ERW or other hazardous objects located at the site shall be recorded in the site documentation (i.e. location, date, type and condition).
- j. Mines/ERW or other hazardous objects remaining at the site at the end of the working day shall be appropriately marked, recorded, and the reason for them remaining shall be recorded in site documentation and detailed in relevant operational reports.